

PV Solar Controller with 100 Watt Module as a STATCOM for Distribution Utility

Rajkumar Chougale¹, Devidas Mahadik^{2*}

¹Electrical Engineering, Bharati Vidyapith's Engineering College, Kolhapur, Maharashtra, India

²Electrical Engineering, Adarsh Institute of Technology (Polytechnic), Vita, Sangli, Maharashtra, India

*Corresponding author: E-Mail: devidasmahadik@gmail.com

ABSTRACT

A PV solar system generates real power in a day and remains completely unutilized in the night. This new concept utilizes PV solar controller work as a STATCOM at the time of night to compensate reactive power and voltage stability. This methodology will also be available upto some limit at the time of day with the rest inverter capacity after the real power generation. During the time of night, when the solar system is completely unutilized, this system makes the solar system along with the controller works like a STATCOM. During the time of day also, when solar panels generating real power, this new control technique makes the solar system with controller acts as a voltage control device with the rest inverter VA capacity which further increases power transfer limits upto some extent by compensating the reactive power, which improves the overall system power factor.

KEY WORDS: PV, Reactive power compensation, Static Synchronous Compensator (STATCOM), PV solar controller as a STATCOM, MATLAB Simulation.

1. INTRODUCTION

Electrical energy is one of the crucial and fundamental inputs required for the nation growth. Today, in India, about 15-20% of electrical energy is lost, often during peak load the voltage profile goes below the accepted level. One of the main reasons for heavy transmission and distribution losses is the high percentage of reactive load. The existence of vastly inductive loads is harmful to the electrical power system and raise of these loads causes to further increase in reactive power requirement thus results poor power factor of the system and hence the higher losses. Therefore needs to neutralise the reactive power, which automatically improves power factor. In PV solar system, PV solar panel along with controller are used to supply reactive power in night time without extra expenditure. This gives a new 24 hour application of a PV solar system, which works as a STATCOM for voltage control and stability. At the time of day, the PV solar system, while supplying real power is made available upto some extent to work as a STATCOM and gives voltage control stability by using rest inverter VA capacity.

This new technique was first implemented by Rajiv (2011). They reported that, PV solar system generates real power in a day and meets the load requirement. At the night time, when the PV solar system with controller is completely unutilized, this control system works PV solar system inverter with controller acts like a STATCOM, which is one of the key FACTS device.

Necessity of Reactive Power Compensation: The existence of loads with large requirement for reactive power is harmful to the power system. This results to heavy raise in the current flow on the power systems and hence contributes to the system losses. Thus supply of more and unnecessary reactive power, as in the case of extremely inductive loads, like industrial furnace etc. has to be prepared at the price of practical power, which not just is uneconomical but also results in the system become unstable, because of restricted capacity of generators to deliver reactive power.

Conventional STATCOM: STATCOM is a voltage-source converter based device that converts a DC input voltage into an AC output voltage to compensate the active and reactive power requirements of the system. STATCOM is one of key FACTS device that can be used for compensation as well as control of power factor. Figure 1 shows a basic STATCOM. In the entire FACTS devices, it is essential that the control tactic be appropriate to have improved and quickly control over power factor compensation. Lots of control techniques for STATCOM are researched previously and all of them can improve reactive power and power factor issues.

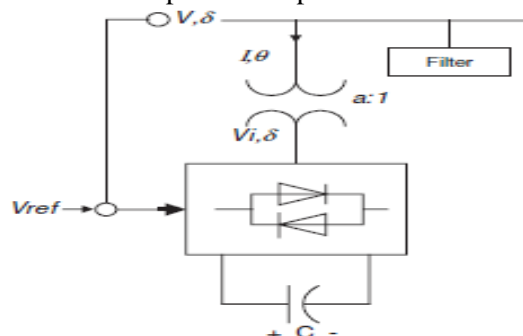

Figure.1. STATCOM Structure

Conventional PV Solar System: A usual PV Solar system catches radiation energy from Sun during day time. In other words, it generates real power during day time and then injects to the grid via inverter. But during the time of night complete PV solar system along with controller remains completely unutilized.

Disadvantages of Conventional PV Solar System:

- Limited power handling capacity of Grid system, as there is no certain adequate provision of reactive power compensation.
- Separate Power factor correction device is essential to raise overall system power factor.
- Poor voltage regulation, because of low lagging power factor.
- Raises overall system price, due to extra cost on power factor correction device.

PV Solar Controller acts as STATCOM: PV Solar controller acts as STATCOM deals with both real as well as reactive power control in grid, which performs two major issues in power system, Firstly the real power demand and Secondly reactive power compensation. This causes to improve the voltage regulation and hence the improved power factor.

Benefits of PV Solar controller acts as STATCOM: This innovative control method of PV Solar controller as STATCOM has lots of benefits in excess of a conventional PV Solar system. These are illustrated below.

- Increased power handling capacity of connected Grid system.
- Improves overall system power factor.
- Improves voltage regulation.
- Cost of PV Solar Controller is lower than a conventional STATCOM.

PWM for MOSFET firing: In the basic PWM method (fig.2) a sinusoidal, fundamental frequency signal is compared against a high frequency triangular signal; that produces a square wave signal, which controls the firing of the converter valves. Which then drives the capacitor & inductor for the reactive power compensation.

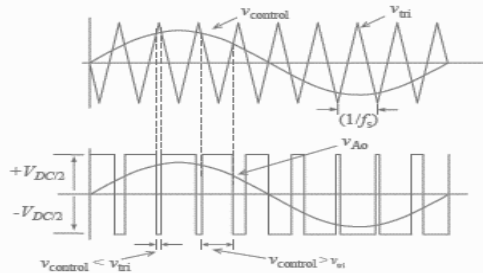

Figure.2. PWM for firing of converter valves

Hardware Design Results:

Hardware design results of 100W PV solar panel: From Power-Voltage Curve, PV solar panel maximum loading capacity can be traced. And as per the measurement, the maximum power delivered by PV Solar panel observed is 96.86 Watt. The DC Power is calculated by;

Power (P) = Voltage (V) × Current (I)

Table.1. Voltage, Power measurements of 100 W Solar module

S.No.	Voltage (V)	Power (P)	S.No.	Voltage (V)	Power (P)
1	21.8	0	9	16.7	96.86
2	21	31.5	10	16	96
3	19.8	59.4	11	14	85.4
4	19.2	67.2	12	11	67.65
5	18.6	74.4	13	8	49.6
6	18.1	81.45	14	4	25
7	17.6	88	15	1.2	7.536
8	17	93.5			

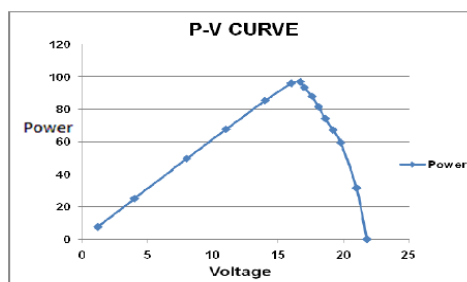

Figure.3. Power-Voltage characteristics of PV Solar system

Power-Time characteristics for real power generation: A 100 Watt PV Solar panel is associated to grid through voltage source inverter in sunny day. The real power consumed by different loading conditions with reference to time is given below.

Table.2. Real Power measurement with respect to time of 100 W Solar module

S.No.	Time (Hrs)	Power (P)	S.No.	Time (Hrs)	Power (P)
1	1	0	13	13	98.4
2	2	0	14	14	97.8
3	3	0	15	15	96.2
4	4	0	16	16	86.2
5	5	0	17	17	60.7
6	6	0	18	18	25.1
7	7	21.2	19	19	0
8	8	40.8	20	20	0
9	9	58.9	21	21	0
10	10	79.5	22	22	0
11	11	90.1	23	23	0
12	12	95.7	24	24	0

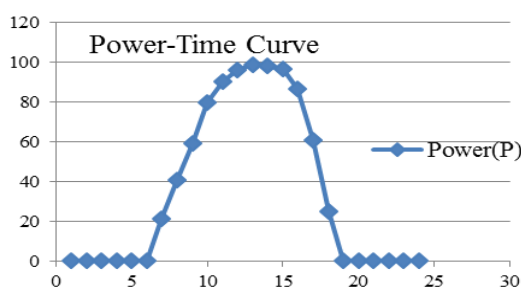

Figure.4. Power-Time characteristics of PV Solar system

Power-Time characteristics for real and reactive power flow: The real and reactive power exchange by 100Watt PV Solar Module with respect to time is illustrated below.

Table.3. Real and Reactive Power exchange with respect to time of 100 W Solar module

S.No.	Time (Hrs)	Power (P)	Power (Q)	S.No.	Time (Hrs)	Power (P)	Power (Q)
1	1	0	100	13	13	98.4	1.6
2	2	0	100	14	14	97.8	2.2
3	3	0	100	15	15	96.2	3.8
4	4	0	100	16	16	86.2	13.8
5	5	0	100	17	17	60.7	39.3
6	6	0	100	18	18	25.1	74.9
7	7	21.2	78.8	19	19	0	100
8	8	40.8	59.2	20	20	0	100
9	9	58.9	41.2	21	21	0	100
10	10	79.5	20.5	22	22	0	100
11	11	90.1	9.9	23	23	0	100
12	12	95.7	4.3	24	24	0	100

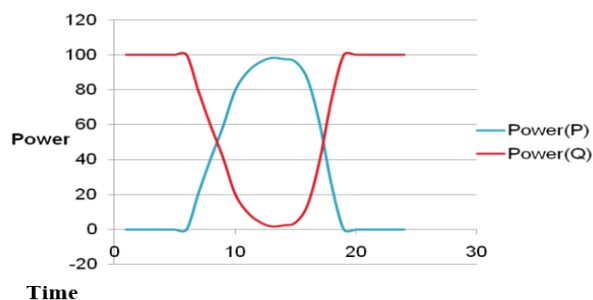

Figure.5. Real and Reactive power exchange characteristics of PV Solar system

The MATLAB simulation provides an idea about the hardware system development of PV solar controller acts as a STATCOM shunt. This also provides output of active and reactive power, voltages and current at unusual loading circumstances.

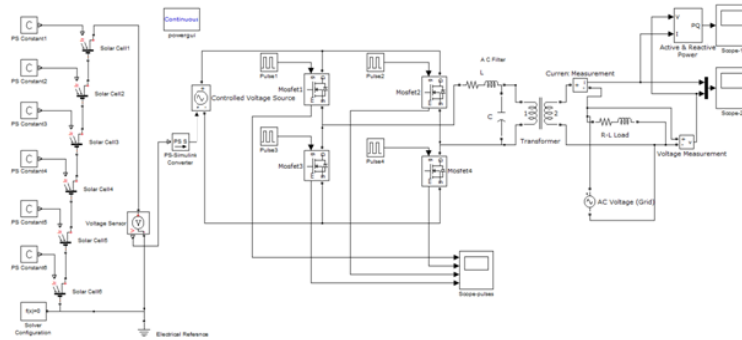

Figure.6. MATLAB simulation with PV solar controller as a STATCOM

Voltage, Current waveforms by MATLAB simulation: Figure.6, shows MATLAB simulation with PV solar controller acts as a STATCOM which is created by using blocks in sim power and sim scape. The solar cells are joined in series to create a string of 20 volt D.C. The radiation is laid down by PS constant and sim power, sim scape blocks are connected by PS simulink converter. Single phase inverter is constructed by four MOSFET blocks with pulse generator. The output of inverter is then made sinusoidal by the use of LC filter and fed to step up transformer to match the grid voltage. The voltage, current and active, reactive power waveforms without and with compensation are obtained by scope as given by figure 7 and 8

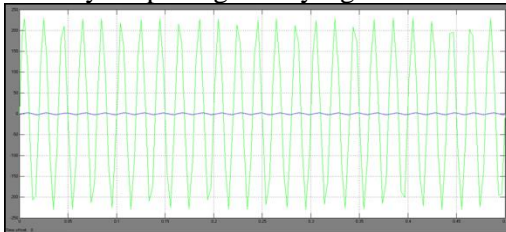

Figure.7. Voltage current waveform without PV solar controller acts as a STATCOM

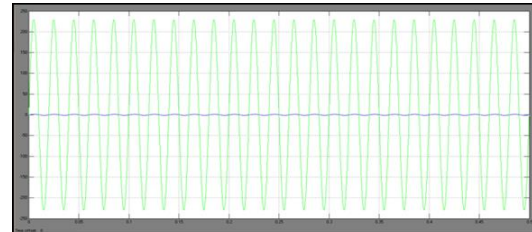

Figure.8. Voltage current waveform with PV solar controller acts as a STATCOM

Active, Reactive power waveforms by MATLAB simulation: Figure.9 and 10, shows active, reactive power waveforms for without and with PV solar controller as a STATCOM respectively. And it is observed that, without compensation the reactive power is comparatively higher and results in fundamental sine wave distortion. On its opposite side, the reactive power is compensated with PV solar controller acts as a STATCOM which causes waveform closer to fundamental sine wave. This is due to the fact that, consuming reactive power by PV solar controller acts as a STATCOM and minimizes reactive power from 100 VAR to 20 VAR.

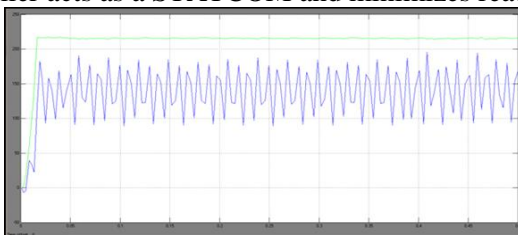

Figure.9. Active Reactive power without PV solar controller as a STATCOM

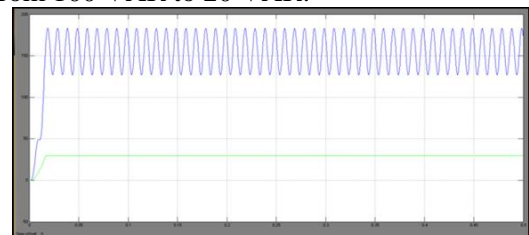

Figure.10. Active Reactive power with PV solar controller as a STATCOM

4. CONCLUSION

It has been observed that, in conventional PV Solar system the overall asset remains idle during night time. Also it requires additional STATCOM for reactive power compensation. With this novel control approach, PV Solar system is utilized for 24 hours. Out of which 12 hours for real power generation during daytime and 12 hours for reactive power compensation during night time, that avoids additional cost of conventional STATCOM.

The reactive power observed without compensation is 105 VAR, with an power factor of 0.65 lagging. On its opposite side, with PV solar controller acts as a STATCOM the reactive power is minimized and the net reactive power is measured as 15 VAR, with an power factor of 0.98, which is comparatively a improved power factor.

REFERENCES

Gyugyi L, Reactive Power Generation and Control by Thyristor Circuits, IEEE Trans. Ind. Appl., 15 (5), 1979, 521-532.

Hadi Saadat, Power System Analysis, Tata McGraw – Hill, New Delhi, 7th edition, 1999.

Kishore A, Hill E.F, Static optimization of reactive power sources by use of sensitivity parameters, IEEE Transactions on power apparatus and systems, 1971, 1166-1173

Kundur P, Power System Stability and Control, EPRI Power System Engineering Series, McGraw-Hill, New York, 1994.

Mathur R.M and Varma R.K, Thyristor Based FACTS controllers for electrical transmission system, New York, Wiley-IEEE press, William D.Stevensen, Elements of Power system Analysis, Jr.4th eiditon, Tata Mc Graw –Hill, International Editions, Electrical and Electronics Engineering series, 2011.

Narain Hingorani G and Laszlo Gyugyi, Understanding FACTS, Concept and Technology of Flexible AC Transmission Systems, IEEE Power Engineering Society, IEEE Press, Standard Publishers Distributors, Delhi, First Indian edition, 2001.

Rajiv Varma K, Shriram Rangarajan S, Iurie Axente and Vinay Sharma, Novel application of a PV Solar Plant as a STATCOM during Night and Day in a distribution Utility Network, Power system conference and Exposition (PSCE), IEEE, 2011.

Rajiv Varma K, Vinod Khadkikar and Ravi Seethapathy, Nighttime application of PV solar farm as a STATCOM to regulate grid voltage, IEEE Trans. On Energy Conversion, 24 (4), 2009.